



Centrifugal pumps
Centrifugal Pumps
Centrifugal pumps



GLOBAL SOLUTIONS

DESIGNING, MANUFACTURING AND PACKAGING FOR THE OIL & GAS INDUSTRY

Beyond Integration
Seamless Solutions™

Centrifugal Pumps

The TSC Highlight™ centrifugal pump features a rugged design with heavy duty construction that reduces downtime and total cost of ownership for operators and contractors in today's highly competitive drilling industry.

MULTIPLE APPLICATIONS

Manufactured from wear resistant materials, the Highlight™ centrifugal pump can be used in a multitude of applications from handling abrasive cements and drilling fluids in the oil and gas industry, to waste disposal applications in the agriculture industry.

DIVERSE OPERATING RANGE

The Highlight™ pump line features seven different fluid end sizes and 100+ impeller sizes for fluid flows from as little as 160 gpm to as much as 2500 gpm.

DIMENSIONAL ENVELOPE

The Highlight™ conforms to the industry standard dimensional envelope in the oil and gas drilling and well service industry.

GLOBAL DISTRIBUTION

TSC has global distribution with offices and distributors located in major geographic oil and gas regions.

PROLONGED RUN TIMES

Wear resistant fluid end materials provide extended run times on critical wear components.

PREVENT COSTLY FAILURES

TSC's 2-1/2" pump shaft is highly resistant to deflections induced by the pump impeller and helps prevent costly failure of optional mechanical seals.

IMPROVED FLUID FLOW

Wide vane impellers allow for improved fluid flow dynamics and high fluid volume.

IMPROVED OVERALL FATIGUE RESISTANCE

Heavy-duty power end construction improves overall fatigue resistance through strengthening mass in critical stress areas.

IMPROVED BEARING LIFE

Heavy duty inboard roller bearings provide additional bearing area for longer bearing and mechanical seal life.

REDUCE MAINTENANCE

Optional mechanical seal reduces maintenance and improves long-term maintenance procedures.

FULL OPEN IMPELLER

Minimizes induced shaft loading.

ENHANCED PUMP EFFICIENCY

Concentric casing reduces turbulence and enhances fluid end life.

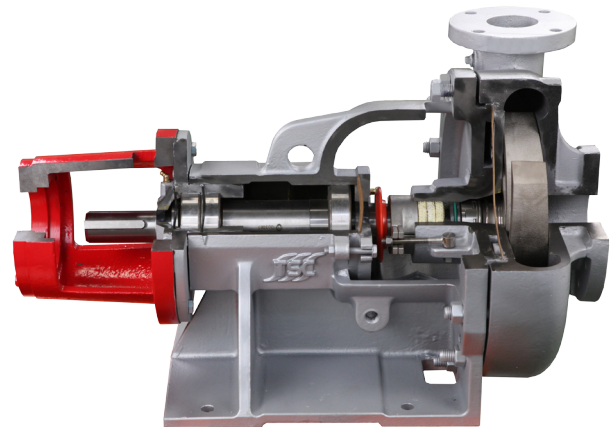

Centrifugal Pumps

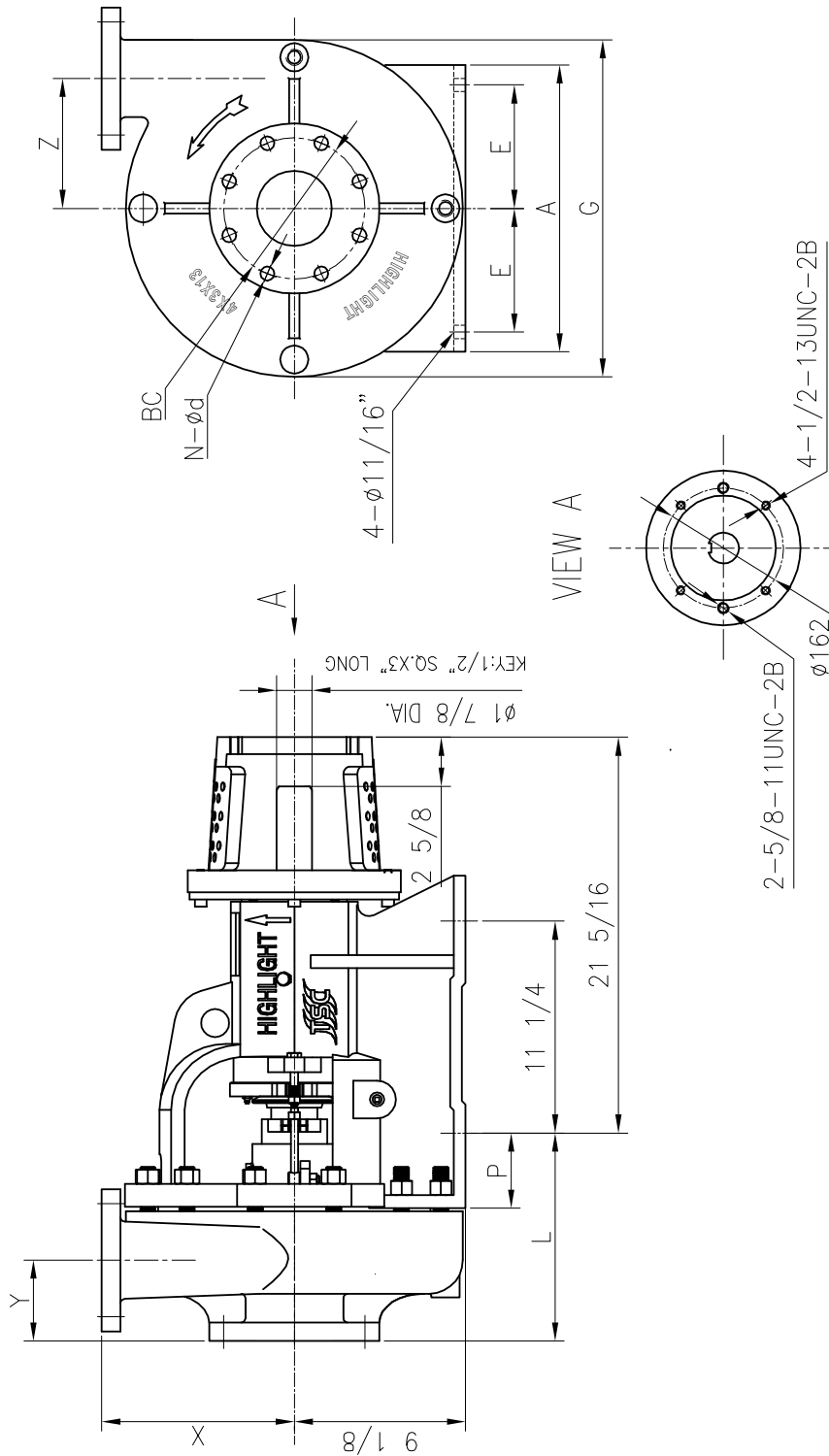

Pump size	Suction flange		Discharge flange		A	B	E	F	G	L	P	X	Y	Z	CP	DD
	Size	n	d	BC												
HCPS3x2x13	3"	4	3/4"	6"	15 1/4"	17 3/4"	6 9/16"	11 1/4"	17 7/8"	10 7/16"	4"	10 1/4"	3 3/4"	7"	25 1/16"	8 15/16"
HCPS4x3x13	4"	8	3/4"	7 1/2"	15 1/4"	17 3/4"	6 9/16"	11 1/4"	17 7/8"	16 1/16"	4"	10 1/4"	4 1/4"	6 3/4"	25 1/8"	8 15/16"
HCPS5x4x14	5"	8	7/8"	8 1/2"	15 1/4"	17 3/4"	6 9/16"	11 1/4"	19"	12 7/16"	4"	11"	5"	6 1/8"	25 13/16"	9 1/2"
HCPS6x5x11	6"	8	7/8"	9 1/2"	15 1/4"	17 3/4"	6 9/16"	11 1/4"	17 7/8"	13 3/4"	4"	11"	5 3/4"	6"	26 3/8"	8 15/16"
HCPS6x5x14	6"	8	7/8"	9 1/2"	15 1/4"	17 3/4"	6 9/16"	11 1/4"	21"	13 3/4"	4"	11"	5 3/4"	6"	26 3/8"	10 1/2"
HCPS8x6x11	8"	8	7/8"	11 3/4"	15 1/4"	17 3/4"	6 9/16"	11 1/4"	20"	14 15/16"	4"	14"	6 1/4"	8 3/8"	27 1/16"	10"
HCPS8x6x14	8"	8	7/8"	11 3/4"	15 1/4"	17 3/4"	6 9/16"	11 1/4"	23 9/16"	14 15/16"	4"	14"	6 1/4"	8 3/8"	27 1/16"	11 13/16"
HCPS10x8x14	10"	12	7/8"	14 1/4"	15 1/4"	17 3/4"	6 9/16"	11 1/4"	22 3/8"	15 3/8"	4"	14 3/16"	6 11/16"	8"	27 1/16"	11 3/16"



Centrifugal Pumps

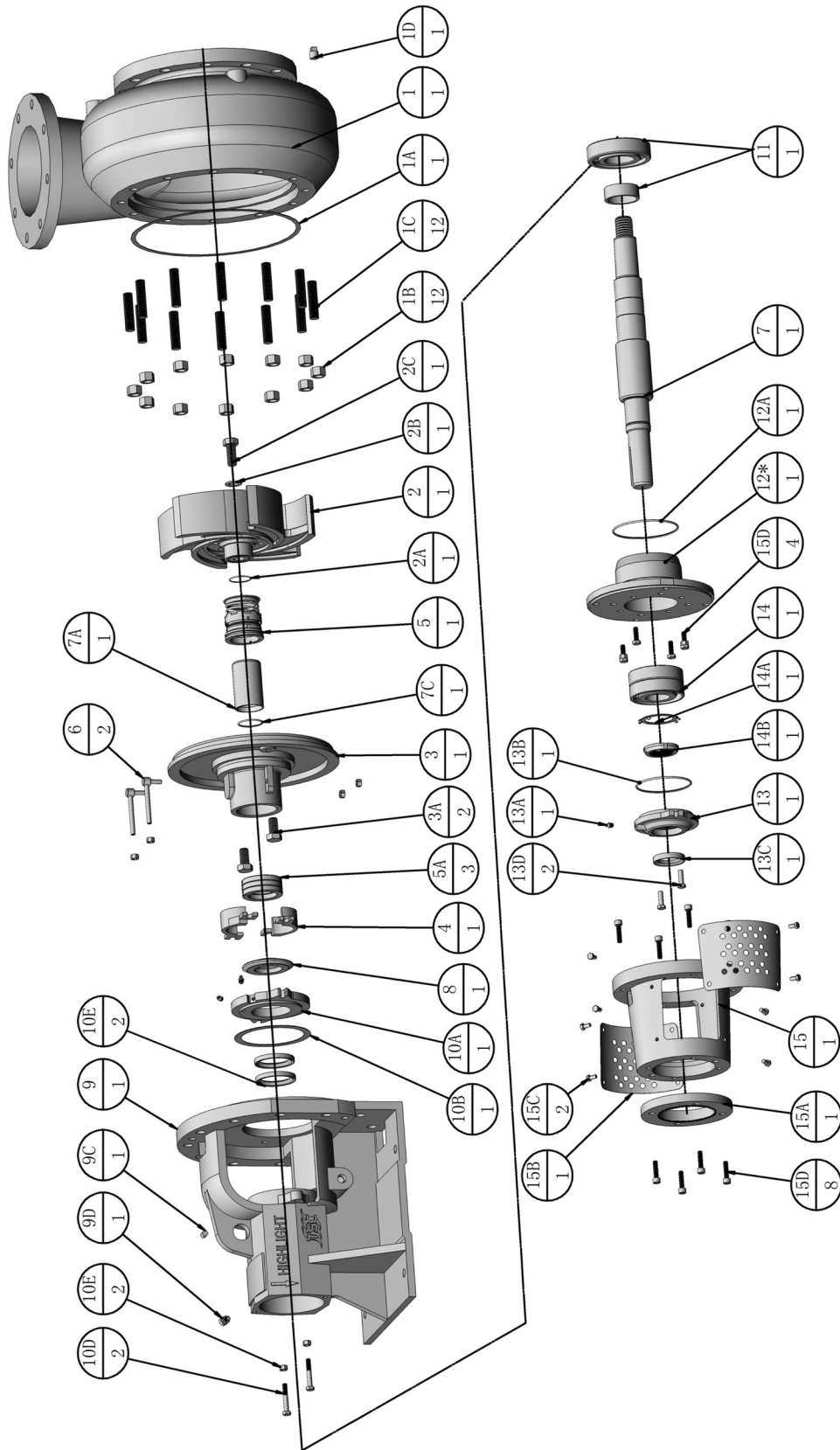

Centrifugal Pumps

No	Qty	NOV Part No	TSC part #	Description	materials	No	Qty	NOV Part No	TSC part No. #	Description	Materials
1*	1	See below	See below	Casing	Hard Iron	10F			N/A		
1A	1	10399-46-1	TS-10399-46-1	Gasket, Casing	Vellumoid	10G	1	21641-01	TS-21641-01	Grease Fitting	Stl
1B	12	3932-61	TS-3932-61	Nut, Casing	Stl	11	1	N/A	TS-661009010	Bearing, Inboard	Vendor
1C	12	3862-76	TS-3862-76	Stud, Casing	Stl	12	1	22224-01-43	TS-22224-01-43	Hydraulic Bearing Housing	Stl
1D	1	8505-4-1	TS-8505-04-01	Plug, Casing Drain	Stl	12A	1	7496-253	TS-7496-253	Seal, O.B. Bearing Housing	Buna-n
1E	1	8505-4-1	TS-8505-04-01	Plug, Flush Line	Iron	13	1	20617-01-01	TS-20617-01-01	Cover, O.B. Bearing	Iron
2*	1	See below	See below	Impeller	Hard Iron	13A	1		TS-661010020	Grease Zerk, O.B. Bearing Cvr.	Stl
2A	1	19110-72	TS-19110-72	Seal, Impeller	Viton	13B	1	7496-26	TS-7496-26	O-ring, O.B. Bearing Cover	Buna-n
2B	1		TS-7300239	Washer, Impeller	Stl	13C	1	20619-02	TS-20619-02	Oil Seal, O.B. Bearing Cover	Buna-n
2C	1		TS-7415648	Bolt, Impeller Lock	Stl	13D	2	3861-139	TS-3861-139	Bolt, O.B. Bearing Cover	Stl
3*	1	22223-01-30	TS-22223-01-30	Stuffing Box, Mech. Seal	Hard Iron	14	1	N/A	TS-648408201S	Bearing, O.B. (2 Req'd)	Vendor
3*	1	20614-01-30	TS-20614-01-30	Stuffing Box, Packed	Hard Iron	14A	1	Apr-24	TS-6124-4	Lockwasher, O.B. Bearing	Stl
3A	2	3861-117	TS-3861-117	Bolt, Stuffing Box	Stl	14B	1	Apr-23	TS-6123-4	Locknut, O.B. Bearing	Stl
3B	1	19368-01	TS-19368-01	Grease Fitting	Bronze	15	1	22225-01-01	TS-22225-01-01	Hydraulic Motor Adapter	Stl
4	1	20622A	TS-20622A	Gland Assy., Packing	Bronze	15A	1	N/A	TS-2273-1	Spacer, Hydraulic Motor	Stl
5	1	22451-1	TS-22451-1	Seal, Mechanical	Tungsten Carbide	15B	1	N/A	TS-HDAGUARDS	Guards, Hydraulic Drive Adapter	304
5A	1	25014-04M-B	TS-25014-04M-B	Packing, Shaft	Kevlar	15C	2	N/A		Bolt, Adapter Guards	Stl
6	2	B3701A	TS-B3701A	Bolt Assy, Gland	Stl	15D	8	N/A		Bolt, Adapter Spacer	Stl
7	1		TS-20612-02-33-S	shaft	AISI 4140						
7A	1	20943-21	TS-20943-21	Sleeve, Shaft (M.S. Pump)	AISI E7140	Casing					
7A	1	20613-21G-7A	TS-20613-21G-7A	Sleeve, Shaft (Pack Pump)	AISI E7140	1*	1	19203-01-30A	TS-19203-01-30A	Casing, 3x2x13	Hard Iron
7B	1	4372-5-21	TS-4372-5-21	Key, Shaft	416SS	1*	1	19205-01-30A	TS-19205-01-30A	casing , 4x3x13	Hard Iron
7C	1	23444-01-72	TS-23444-01-72	Seal, Shaft Sleeve	Viton	1*	1	19222-01-30A	TS-19222-01-30A	casing , 5x4x11	Hard Iron
8	1	22210-1A	TS-22210-1A	Deflector Assembly	Bronze	1*	1	19122-01-30A	TS-19122-01-30A	casing , 6x5x11	Hard Iron
9	1	20938-02-01	TS-20938-02-01	frame	Cast Iron	1*	1	19123-01-30A	TS-19123-01-30A	casing , 6x5x14	Hard Iron
9A			N/A			1*	1	19763-01-30A	TS-19763-01-30A	casing , 8x6x11	Hard Iron
9B			N/A			1*	1	19117-01-30A	TS-19117-01-30A	casing , 8x6x14	Hard Iron
9C	1	May-05	TS-8505-05	Plug, Oil Drain	Iron	1*	1	20937-01-30A	TS-20937-01-30A	casing , 10x8x14	Hard Iron
9D	1	Jan-67	TS-8267-01	Breather	Stl	Impeller					
9E			N/A			2*	1	19204-XX-30	TS-19204-XX-30	Impeller, 3x2x13	Hard Iron
9F	1		JB/T9740.3-1995	Oil cup: B18	Al	2*	1	19206-XX-30	TS-19206-XX-30	Impeller, 4x3x13	Hard Iron
9G	3	2538-1H	TS-2538-1H	Bolt, casing jack	Stl	2*	1	19224-XX-30	TS-19224-XX-30	Impeller, 5x4x14	Hard Iron
10A	1	20626	TS-20626	Cover, Inboard Bearing	Iron	2*	1	19121-XX-30	TS-19121-XX-30	Impeller, 6x5x11	Hard Iron
10B	1	20625	TS-20625	Gasket, I.B. Bearing Cover	Vegetable Fiber	2*	1	19121-XX-30	TS-19121-XX-30	Impeller, 6x5x14	Hard Iron
10C	1	20619-01	TS-20619-01	Oil Seal, I.B. Bearing Cover	Buna-n	2*	1	19121-XX-30	TS-19121-XX-30	Impeller, 8x6x11	Hard Iron
10D	2	Jan-61	TS-3861-1	Bolt, I.B. Bearing Cover	Stl	2*	1	19116-XX-30	TS-19116-XX-30	Impeller, 8x6x14	Hard Iron
10E	2	Feb-32	TS-3932-2	Nut, I.B. Brg. Cover	Stl	2*	1	21867-XX-30	TS-21867-XX-30	Impeller, 10x8x14	Hard Iron

Centrifugal Pumps

ISO 9001:2008

DNV



TSC Manufacturing and Supply LLC, 13788 West Road, Suite 100, Houston, Texas 77041, USA
Tel: +1 832 456 3900 Fax: +1 832 456 3998 Email: sales@t-s-c.com
Visit our Website at www.t-s-c.com